

**2009  
GL1800  
GOLDWING  
OWNER'S MANUAL  
AIRBAG SUPPLEMENT**

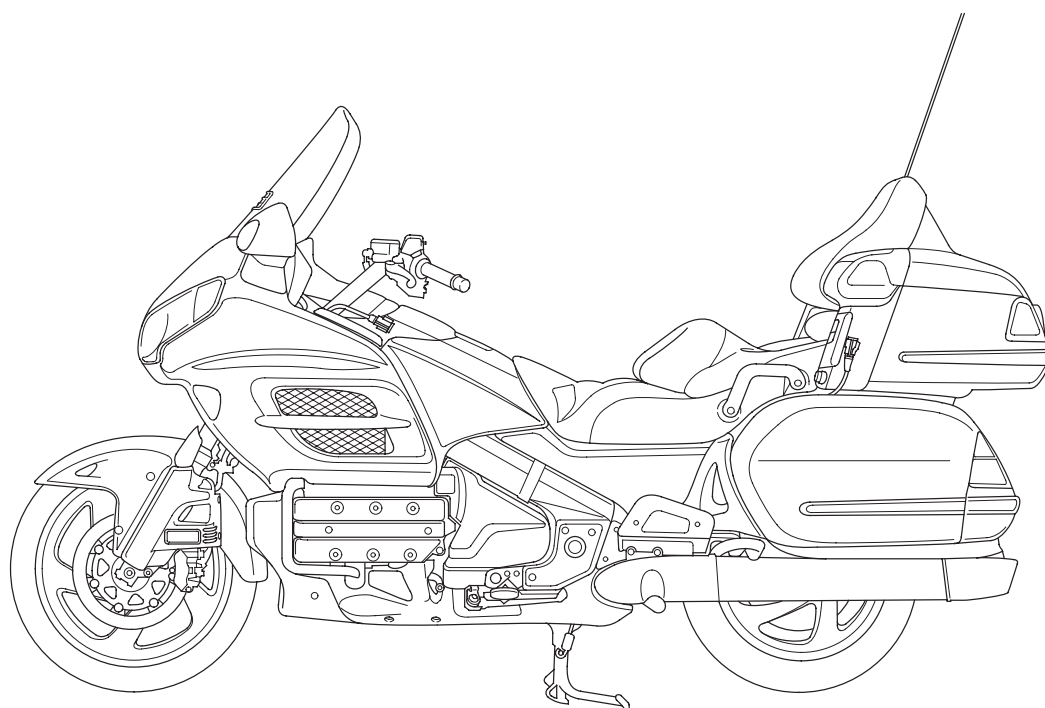

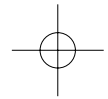

# Introduction

---

Congratulations on choosing a GOLDWING motorcycle.

Your GOLDWING is a very special model, as it is the first production motorcycle in the world equipped with an airbag.

As the ultimate GOLDWING, your vehicle also includes a sophisticated audio system, an anti-lock brake system (ABS), Tire Pressure Monitoring System (TPMS), a multi information display, a navigation system, and a comfort package.

This booklet is a supplement to your owner's manual. The first section explains what the airbag is designed to do, how the motorcycle airbag system works, what special precautions you should take, and when you need to have the system checked by a dealer.

The rest of this supplement follows the organization of the owner's manual, showing you where all your operational, audio, and service controls are located.

Before operating your GOLDWING, please read your owner's manual and this supplement carefully. If you have any questions or need special service, remember that Honda dealers know your vehicle best, and they are the only ones qualified to service your airbag system.

## Event Data Recorders

**This vehicle is equipped with one or more devices commonly referred to as event data recorders. These devices record airbag deployment data, and the failure of any airbag system component.** This data belongs to the vehicle owner and may not be accessed by anyone else except as legally required or with the permission of the vehicle owner.

# A Few Words About Safety

---

Your safety, and the safety of others, is very important. And operating this motorcycle safely is an important responsibility.



To help you make informed decisions about safety, we have provided operating procedures and other information on labels, in the owner's manual, and in this supplement. This information alerts you to potential hazards that could hurt you or others.

Of course, it is not practical or possible to warn you about all hazards associated with operating or maintaining a motorcycle. You must use your own good judgment.

You will find important safety information in a variety of forms, including:

- **Safety Labels** — on the motorcycle.
- **Safety Messages** — preceded by a safety alert symbol  and one of three signal words: **DANGER**, **WARNING**, or **CAUTION**.

These signal words mean:

 <b>DANGER</b>	<b>You WILL be KILLED or SERIOUSLY HURT if you don't follow instructions.</b>
 <b>WARNING</b>	<b>You CAN be KILLED or SERIOUSLY HURT if you don't follow instructions.</b>
 <b>CAUTION</b>	<b>You CAN be HURT if you don't follow instructions.</b>

- **Safety Headings** — such as Important Safety Reminders or Important Safety Precautions.
- **Instructions** — how to use this motorcycle correctly and safely.

This airbag supplement and your owner's manual are filled with important safety information — please read them carefully.

## Safety Messages

# Contents

---

The Motorcycle Airbag .....	1
Important Safety Precautions .....	3
Airbag System Components .....	4
How The Airbag System Works .....	6
Airbag System Service .....	7
Safety Labels .....	8
Instruments & Controls .....	9
Operation Component Locations .....	10
Gauges & Indicators .....	11
Operation Controls & Features .....	12
Headlight Beam Adjustment Switch .....	13
Audio Systems .....	15
Audio Component Locations .....	15
Audio Systems Controls .....	16
Servicing Your Honda .....	17
Maintenance Component Locations .....	17



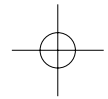

# The Motorcycle Airbag

---

This section of your owner's manual supplement describes the components of your motorcycle airbag system and explains how the airbag is designed to work. It also discusses how to care for a motorcycle equipped with an airbag, and offers some important safety precautions.

The airbag system is an integral part of your motorcycle and is covered by your new vehicle warranty.

The most important things you need to know about your airbag are:

- ***The airbag has a limited but very important role.*** The airbag can reduce the severity of injuries and help save your life in certain severe frontal impacts. It cannot prevent all injuries or deaths that can occur in a crash, and some crashes are too severe for any safety feature or system to prevent death.
- ***The airbag is designed to deploy in a severe head-on or nearly head-on frontal impact.*** The impact can be with another vehicle or an object, such as a concrete highway barrier. A severe frontal impact is one in which the rider would be thrown forward off the front of the motorcycle.
- ***The airbag might deploy in a severe angled frontal collision, or in a sideswipe, or if the motorcycle underrides the rear of another vehicle.*** However, because there are many variables in a collision, the airbag might not be able to reduce the severity of injuries to the rider.
- ***The airbag might deploy if the front tire drops into a sharp depression, such as a pothole, or strikes a hard raised object, such as a curb.*** A brief high rate of deceleration can cause the airbag to deploy, even though it would not be needed.

(cont'd)

# The Motorcycle Airbag

---

- ***The airbag is designed to help protect the rider.*** It is not designed to help protect a passenger.
- ***The airbag is not intended to replace a helmet.*** Helmets have proven effective in reducing the severity of head injuries in all types of crashes. So always wear a helmet, and make sure a passenger wears one as well.

***What you should do:*** Follow all recommendations in this supplement and in your owner's manual.



# Important Safety Precautions

---

- ***Do not install or temporarily attach any items, such as a map holder, over the airbag cover or in the area between the rider's seat and the handlebars.*** This could prevent the airbag from deploying properly, or cause items to be propelled by the airbag and possibly hurt someone.
- ***Do not install any items on the forks.*** This could interfere with the proper operation of the crash sensors.
- ***Do not tamper with any system components, including the yellow wires or connectors.*** Doing so could prevent the airbag system from operating properly or cause unintended airbag deployment and possibly serious injury.
- ***Do not attempt to remove any airbag components — even temporarily.*** This could result in unintended airbag deployment and injury.



# Airbag System Components

---

Your motorcycle airbag system includes:

- An airbag that is stored forward of the rider's seat, under a cover marked "AIRBAG."

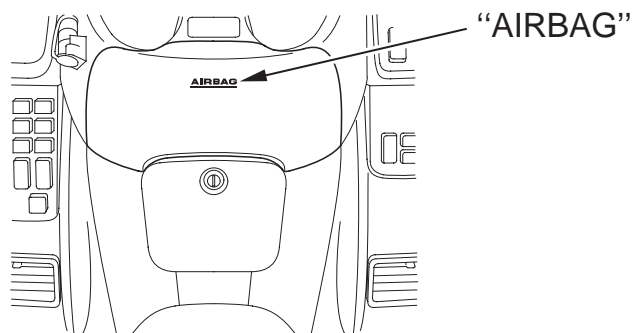

- Four crash sensors; two on the left fork and two on the right fork. The sensors measure the rate of deceleration during a frontal impact.
- A control unit that evaluates data from the crash sensors and determines whether or not the airbag should deploy.

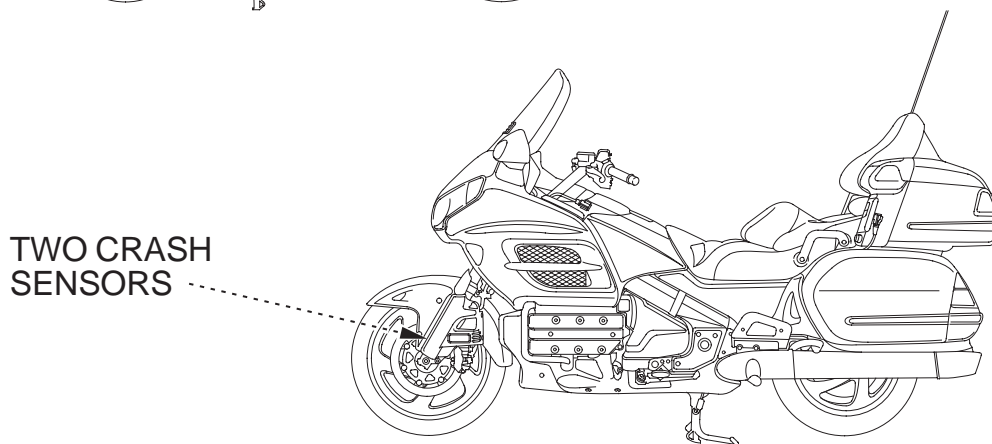
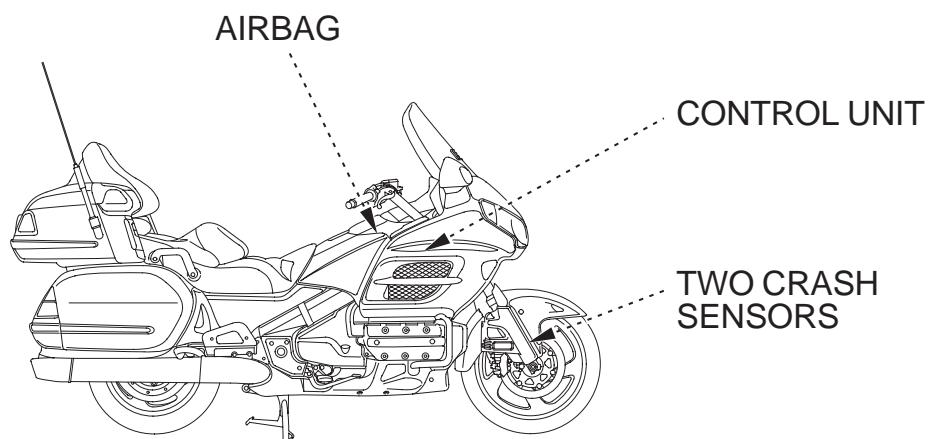

# Airbag System Components

---

- A sophisticated electronic system that continually monitors information about the sensors, the control unit, and the airbag inflator whenever the ignition is in the ON position.
- An indicator on the instrument panel that alerts you to a possible problem with the airbag system (see page 11 for more information).



- Emergency backup power in case your vehicle's electrical system is disconnected in a crash.

# How The Airbag System Works

---

If you ever have a frontal impact, sensors will detect the vehicle's deceleration and send that information to the control unit. If the rate of deceleration is high enough, the control unit will signal the airbag to instantly inflate. Tethers help keep the airbag upright.

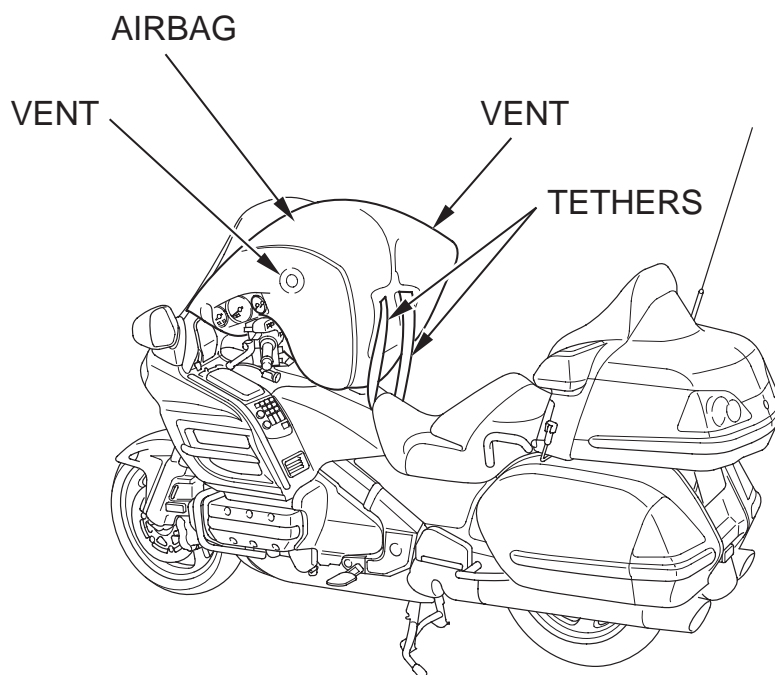

As the rider's head and upper body press into the airbag, the bag immediately begins deflating, through vents located at the top of the bag. The airbag slows down the rider's forward movement and absorbs some of the rider's kinetic energy.

When the rider eventually separates from the vehicle and contacts the opposing object or the ground, the forward speed of the rider and the resulting force of the impact will be much lower than they would be without the airbag.

# Airbag System Service

---

Your airbag system is well protected from the elements. There is no need to take any special precautions to protect it from rain, snow, or temperature extremes.

The airbag system is also virtually maintenance free, and there are no parts you can safely service. However, you must have your motorcycle checked by a Honda motorcycle dealer if:

- ***The airbag indicator alerts you to a potential problem with the system.*** The indicator, located in the instrument panel, should come on briefly when you turn the ignition switch to the ON position. If it does not come on, or it comes on and stays on, or it comes on while you are riding, the airbag may not deploy when you need it.
- ***The airbag ever inflates.*** Any airbag that has deployed must be replaced along with the control unit and other related parts. Do not try to remove or replace the airbag by yourself. This must be done by a Honda dealer.

# Safety Labels

Your motorcycle has two labels with important information about your airbag system. Motorcycle owners are encouraged not to attempt servicing the airbag system. Please refer to the safety label pages in your owner's manual for information about additional safety labels on your vehicle.

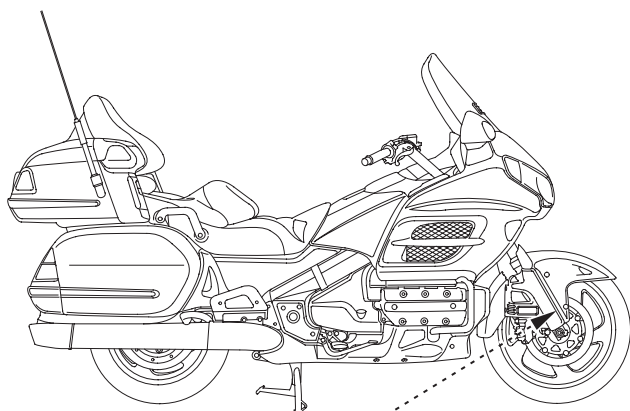

**▲ WARNING**  
Airbag system wires and connectors are yellow. Tampering with, cutting, splicing, or disconnecting yellow wires/connectors could cause airbag deployment or a system failure resulting in serious injury or death.

**EQUIPPED WITH AIRBAG**

All airbag system wires/connectors are yellow. Disconnecting, tampering with, or using test equipment on any yellow wires or connectors can cause system damage or accidental deployment.

**▲ WARNING**  
Unexpected deployment could cause serious injury to you or others. Carefully follow the Service Manual instructions.

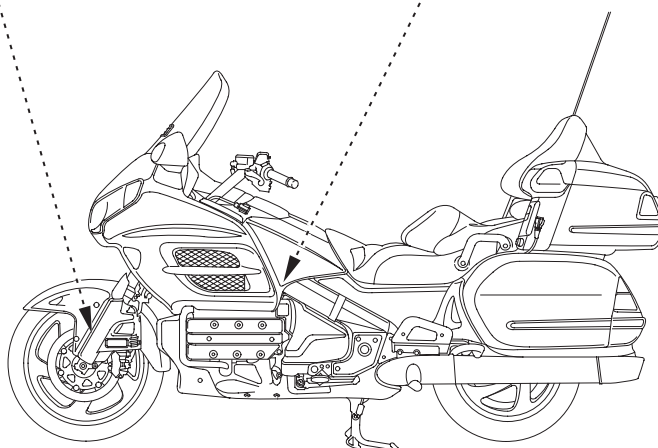

# Instruments & Controls

---

This section shows the location of all controls, gauges and indicators you would normally use before or while riding your motorcycle.

This supplement includes information only for operating items that are unique to your GOLDWING model. For all other controls and features, please refer to your owner's manual.



# Operation Component Locations

Most controls on your GOLDWING are in the same locations as they are on other models equipped with the navigation system. However, in order to provide adequate space for storing and deploying your airbag, some controls have been moved from the center of the vehicle to the fairing panels and handlebars.

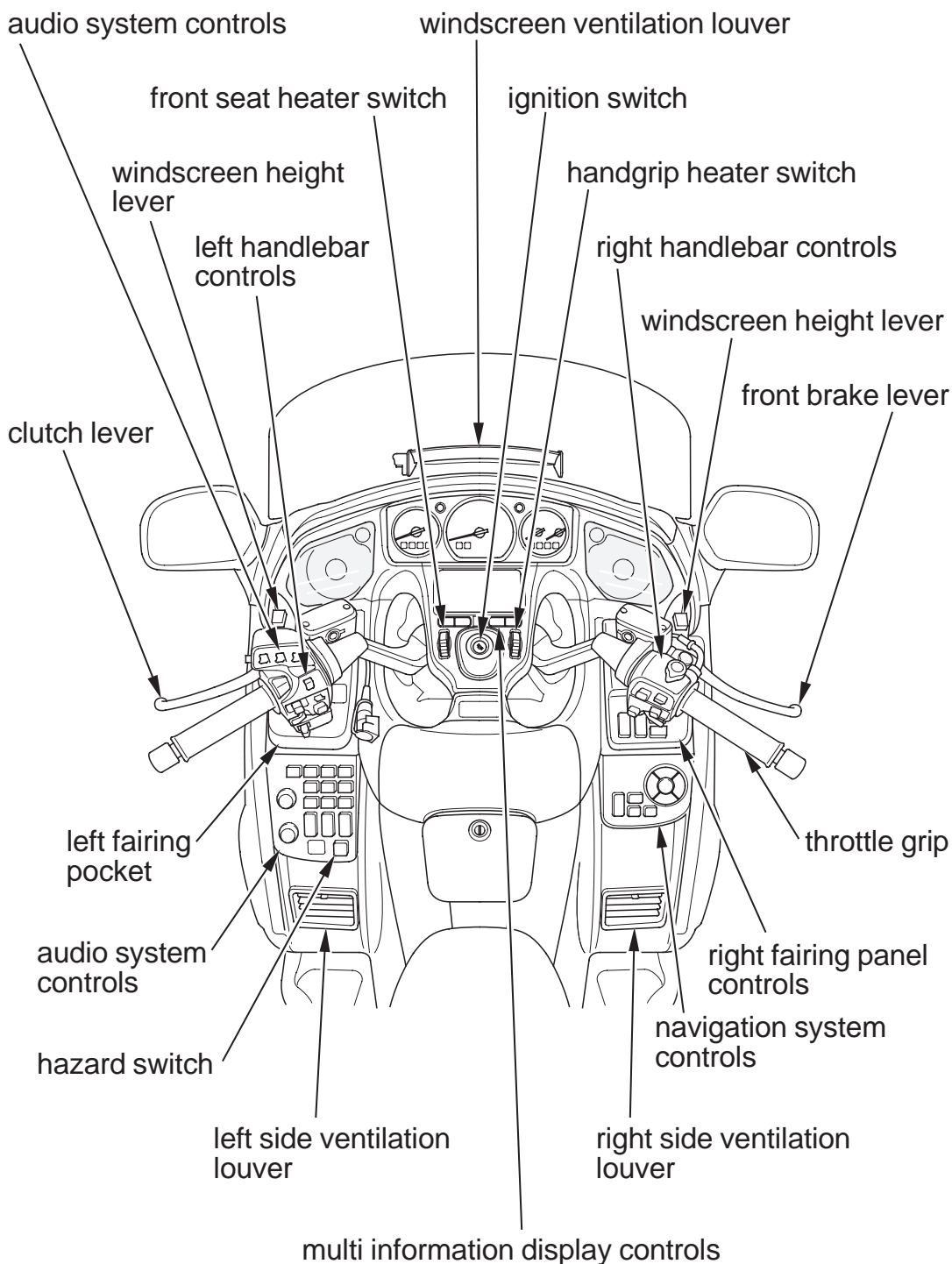



# Gauges & Indicators

The instrument panel on your vehicle includes an airbag indicator, as shown and described below. Please refer to your owner's manual for locations and explanations of the other gauges and indicators on the instrument panel.

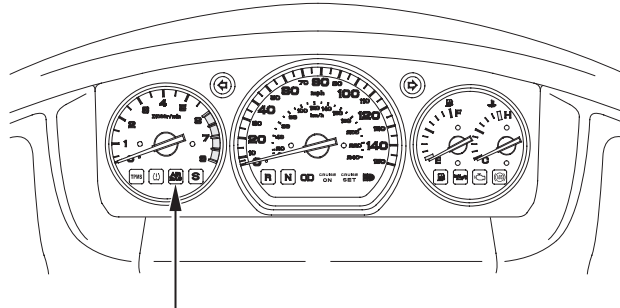

airbag indicator



airbag indicator (red)

This indicator lights when there may be a problem with your airbag system. It should also light for a few seconds and then go off when the ignition switch is turned to the ON position. If the indicator does not come on, or comes on and stays on, or comes on while you are riding, have your motorcycle inspected as soon as possible as the airbag may not deploy when it could help save your life.

## **⚠ WARNING**

Ignoring the airbag indicator can result in serious injury or death in a severe frontal impact if the airbag system does not work properly.

Have your vehicle checked by a dealer as soon as possible if the airbag indicator alerts you to a possible problem.

# Operation Controls & Features

## Fairing Panel Controls & Features

On your GOLDWING, the Hazard Warning System Switch is located on the left fairing panel (see page 16 for the other left fairing panel controls). The right fairing panel on your vehicle includes the Headlight Beam Adjustment Switch and the Rear Suspension Spring Pre-load Adjustment Switch.

Instructions for operating the Headlight Beam Adjustment Switch are on page 13 . Please refer to your owner's manual for more information about the other switches.

LEFT SIDE

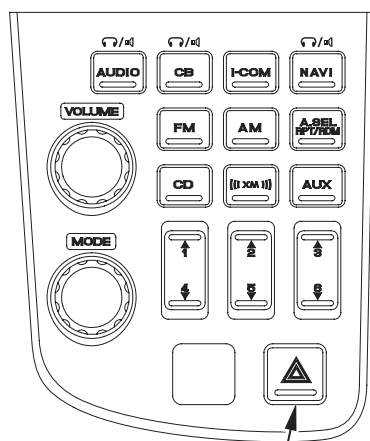

hazard warning system switch

RIGHT SIDE

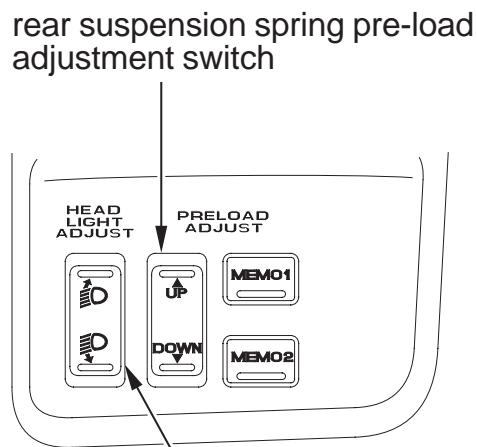

headlight beam adjustment switch

# Operation Controls & Features

---

## Headlight Beam Adjustment Switch

The adjustment switch is used to raise or lower the height of the headlight beam. You can confirm the headlight beam position by referring to the multi information display.

If you carry a heavier or lighter than normal load, you may need to adjust your headlight beam so you can better see the road ahead and don't blind oncoming drivers. Obey local laws and regulations concerning headlight adjustment.

To operate, adjust the Headlight Beam Adjustment Switch when the engine is started and your motorcycle is stopped.

The headlight beam adjustment has 11 positions (from 0 to 10) for different riding conditions. (Standard position is 10.)

# Operation Controls & Features

To lower the beam, push the Headlight Beam Adjustment Switch down (  ).  
To raise the beam, push the Headlight Beam Adjustment Switch up (  ).

## RIGHT SIDE

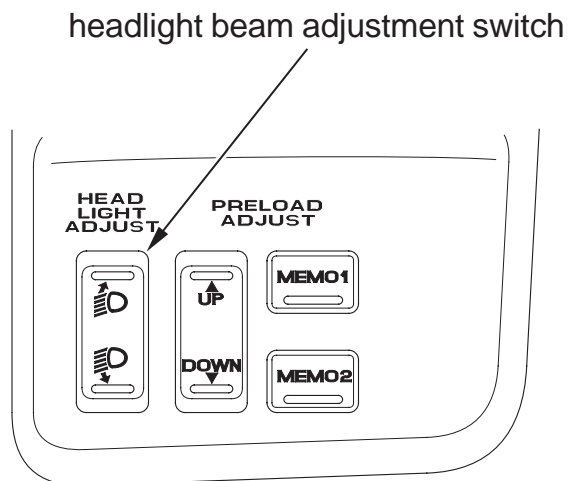

## To Lower

For USA

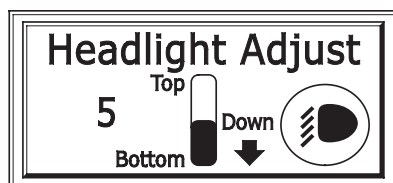

For Canada

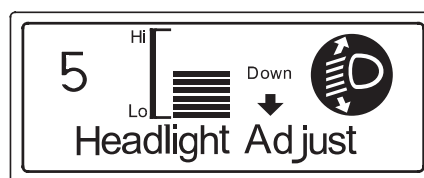

## To Raise

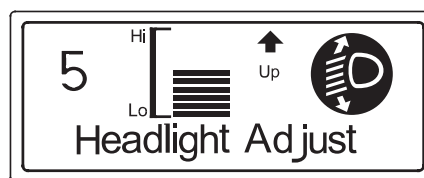
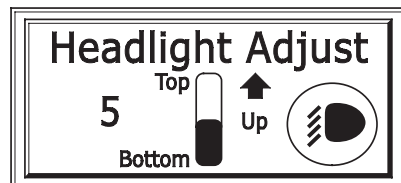

When approximately 5 seconds pass without operating the Headlight Beam Adjustment Switch, the display automatically returns to the previous display.

# Audio Systems

This section shows the locations of all controls and components of your audio systems, including your radio, intercom, and navigation systems. The only difference between your GOLDWING model and others is that some controls are on the left fairing panel. Please refer to your owner's manual for operational instructions.

## Audio Component Locations

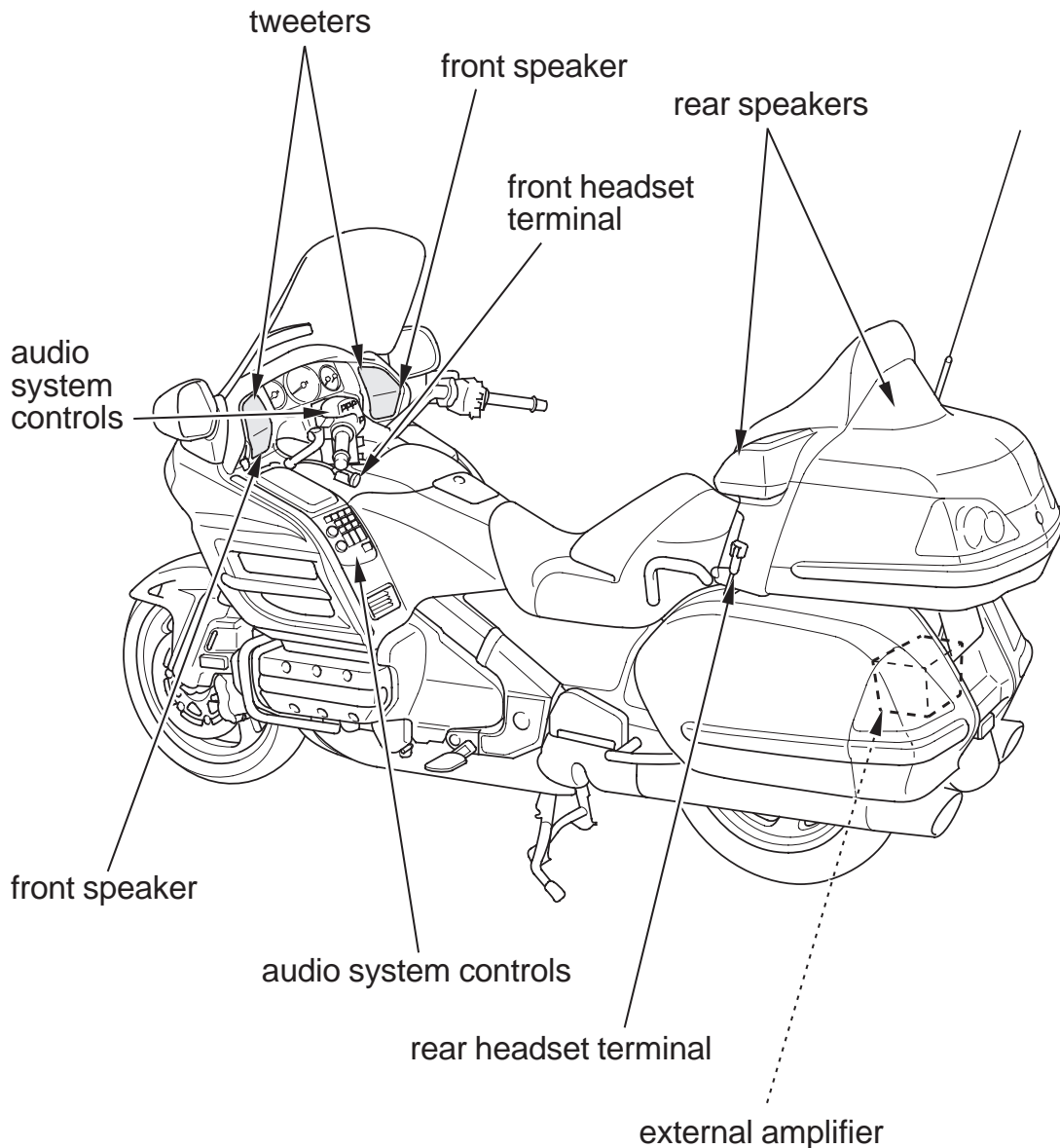

# Audio Systems

## Audio Systems Controls

### LEFT HANDLEBAR CONTROLS

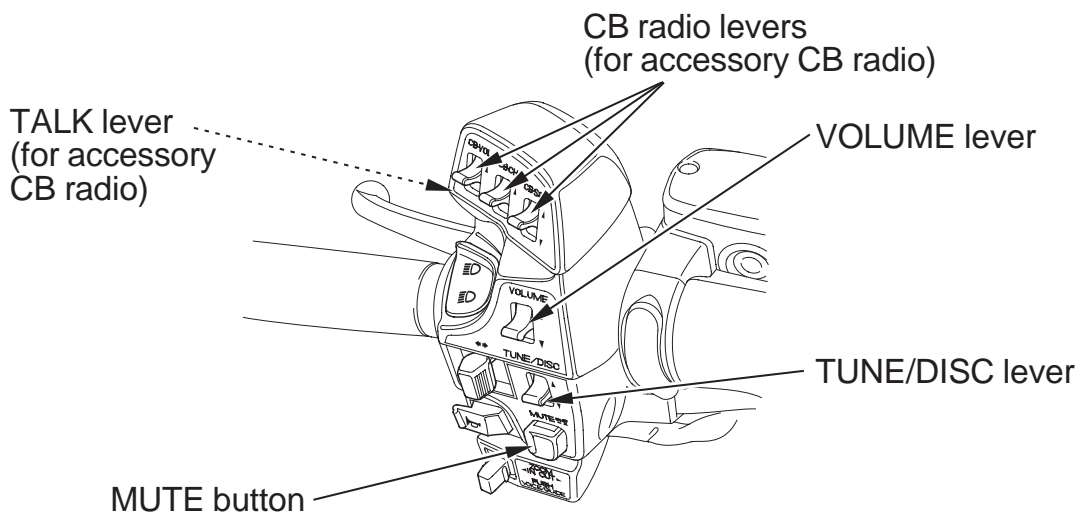

### LEFT FAIRING PANEL CONTROLS

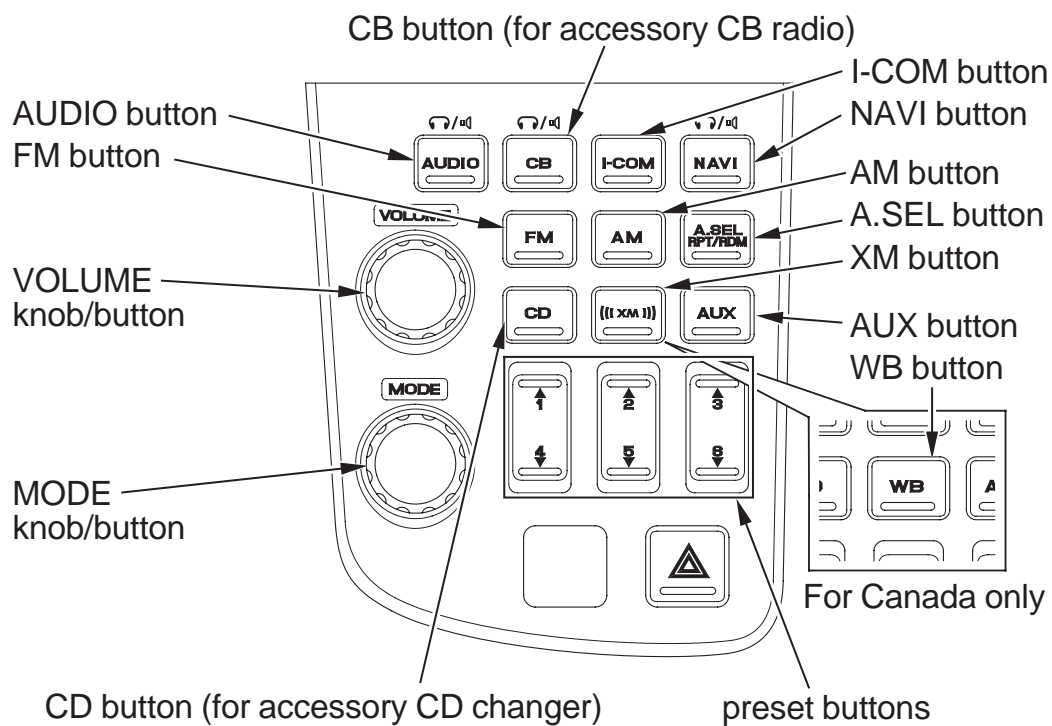

# Servicing Your Honda

The location of service-related components on your vehicle are the same as on all other GOLDWINGS, except for the rear suspension spring pre-load adjustment switch and the headlight beam adjustment switch, which are located on the right fairing panel. Please refer to your owner's manual for information on how to adjust these controls, and for all other instructions on how to keep your motorcycle in good and safe operating condition.

Remember, there are no airbag system parts that you can safely service. While performing routine maintenance, do not remove or tamper with any airbag system components, including the yellow wiring and connectors. Doing so could prevent the airbag from operating properly or cause it to deploy unexpectedly. If an airbag system component needs to be removed in order to reach a serviceable part, it must be done by a Honda dealer.

## Maintenance Component Locations

